

KREA TOUCH

USER CLEANING GUIDE

OPERATED BY

LAVAZZA

PROFESSIONAL

KREA TOUCH

Below are some simple instructions for loading products and cleaning your appliance.



Warnings are highlighted with this symbol



TOUCH SCREEN

LOCK

CUP SENSOR

CUP SUPPORT

LIQUID RESIDUE TRAY

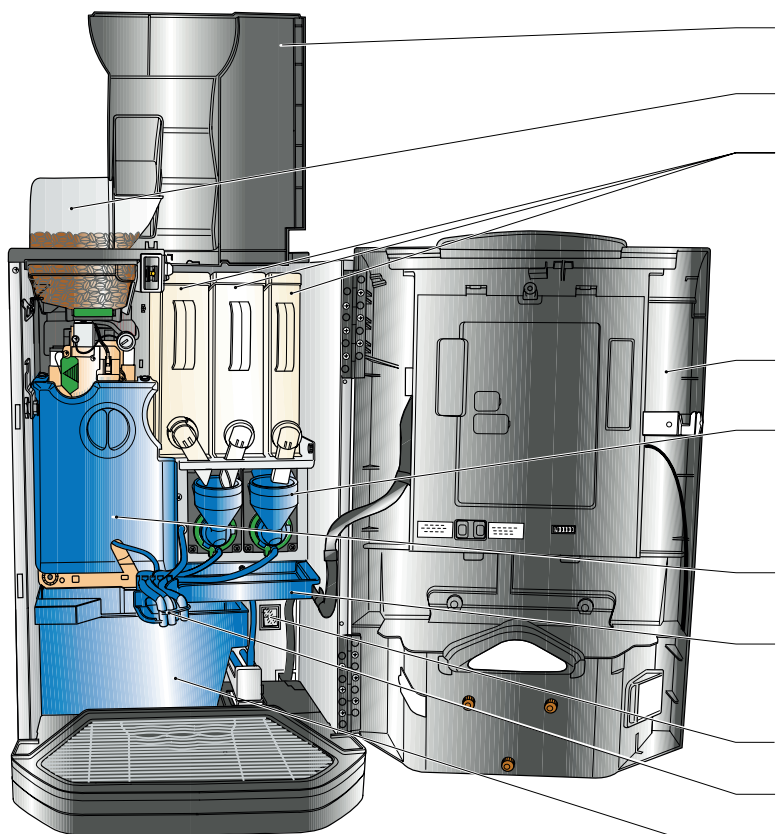

UPPER PANEL

COFFEE BEAN CONTAINER

SOLUBLE POWDER CONTAINER

DOOR

MIXER

BREWING UNIT COVER

MIXER TRAY

ON / OFF SWITCH

NOZZLES

SOLID RESIDUE TRAY

PRODUCT LOADING

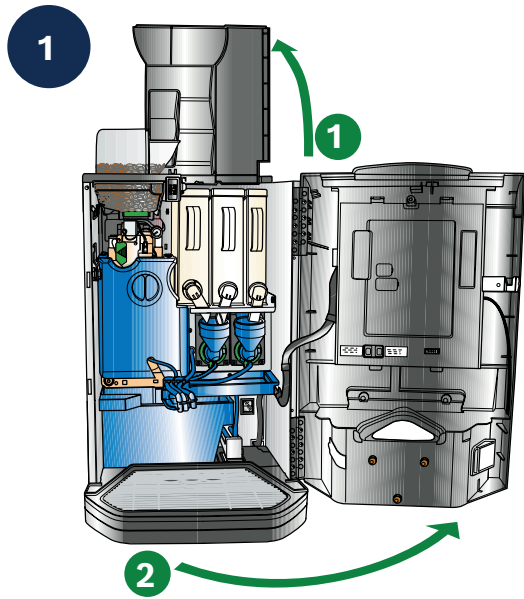

- 1 Lift the upper panel.
- 2 Open the appliance door.



Ensure that the products to be loaded have been stored correctly and have not expired.

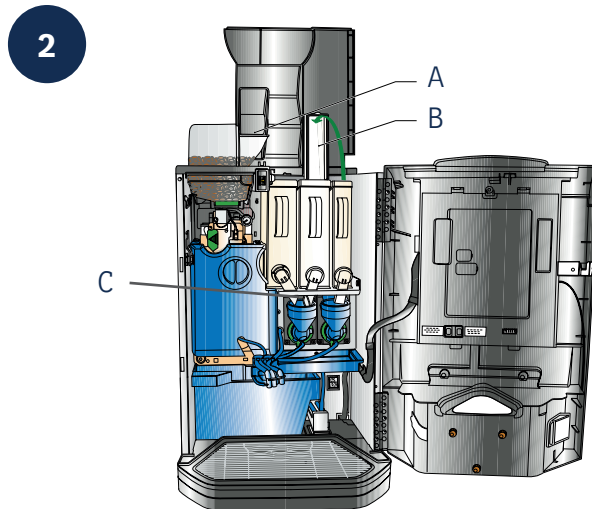

- 3 Load coffee beans through the port (A).
- 4 Load the soluble products into container (B), making sure that the powder is not compressed.
- 5 Wipe the edge of the soluble product chutes with a clean, dry cloth to remove any excess powder (c).
- 6 If the soluble product level control is active, use the "Daily operations" function in the menu to enter the quantity of product loaded.

TRAY CLEANING Daily Cleaning Recommended

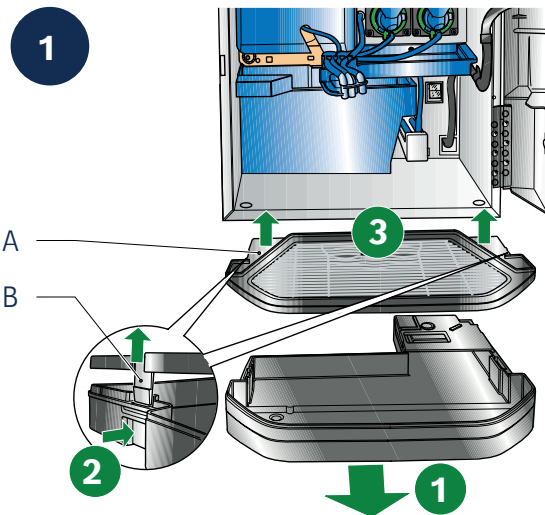

LIQUID RESIDUE TRAY

- 1 Tray should be emptied daily or when the message 'TRAY FULL' is displayed.
- 2 Grab the tray on its sides, lift slightly and pull and then empty the tray.
- 3 Press on hook B to unhook lid A of the liquid residue tray.
- 4 Wash the tray and refit.

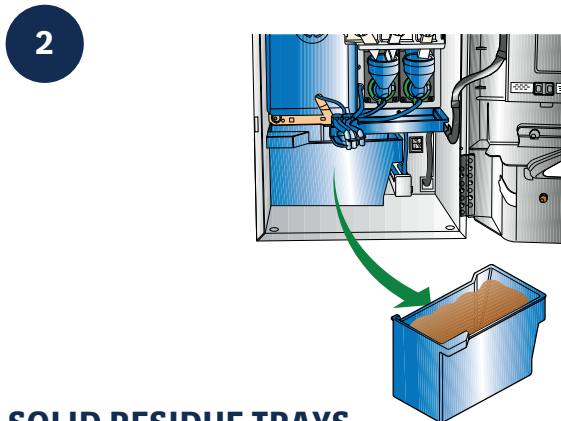

SOLID RESIDUE TRAYS

- 1 Tray should be emptied daily or when the message 'Solid residue tray' is displayed.
- 2 Grab the liquid residue tray on its sides, lift slightly and pull.
- 3 Remove the solid residue tray, empty and wash it.
- 4 Reposition the tray in the reverse order.
- 5 From the "daily operations" functions in the menu, reset the counter that manages the "solid residue tray" function.

OPERATED BY

LAVAZZA
PROFESSIONAL

“DAILY OPERATIONS” FUNCTION

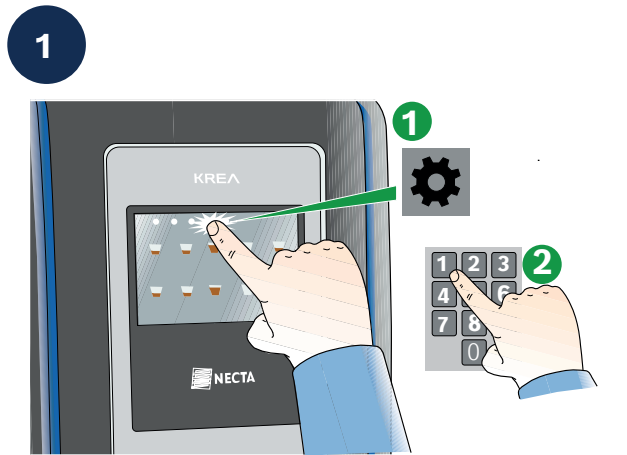

Write down the programmed access password

- 1 From the selection screen, tap to access the menu
- 2 Enter the programmed password.

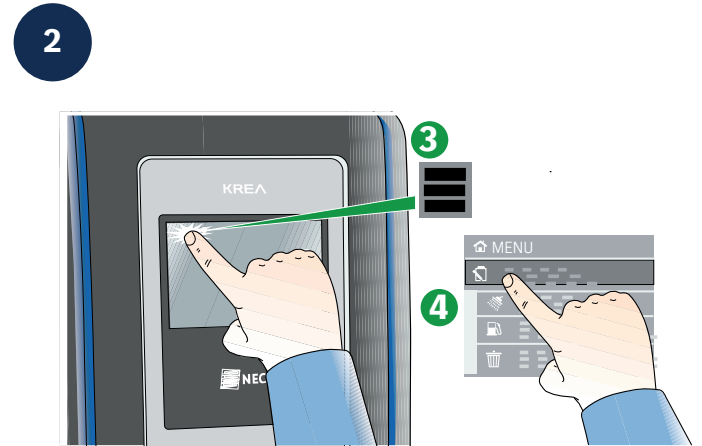

- 3 Tap to access the menu.
- 4 Touch the “daily operations” function.
 - Container filling: to indicate the quantity of product loaded.
 - Residue product reset: to cancel the “residue tray full” display
 - Washing functions
- 6 Tap and then to exit the menu

MIXER AND NOZZLE CLEANING Daily Cleaning Recommended

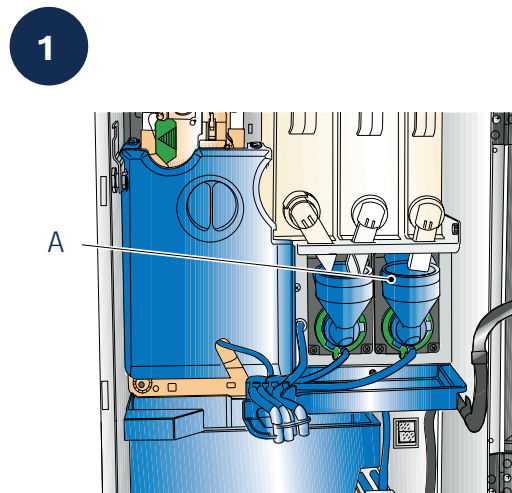

CLEANING THE MIXER BOWL

- 1 Wipe the edge of the mixer bowls with a damp cloth (A).
- 2 Close the door, then from the “daily operations” functions in the menu, rinse the mixer bowls.



To avoid altering the taste of drinks, do not use highly scented detergents or cloths.

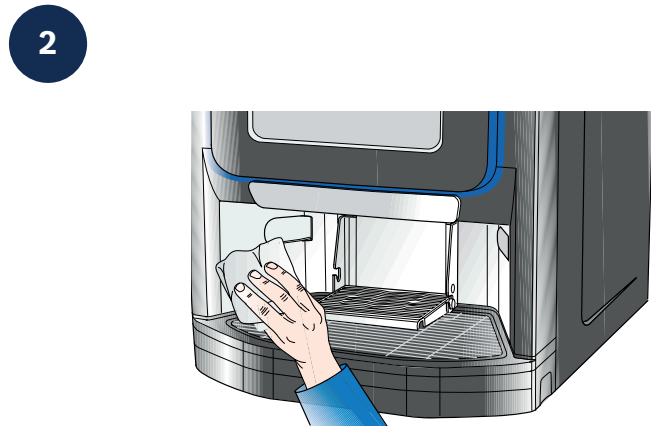

To avoid oxidation or chemical aggression risks, use neutral cleaning products (avoid using solvents)

BREWING UNIT CLEANING

To clean the dispensing compartment and the cup holder, use a soft cloth moistened with cleaning solution.

For the cup sensor to work properly, the sensor window must be kept clean.

MIXER AND NOZZLE CLEANING Weekly Cleaning Recommended

1

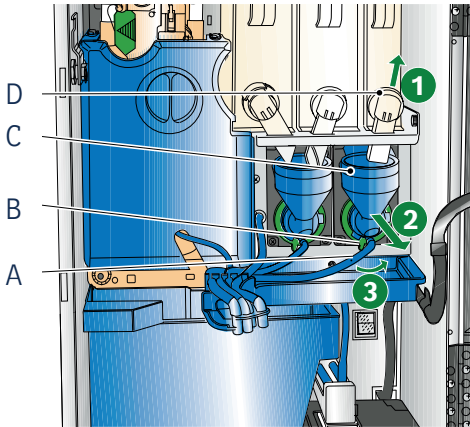

2

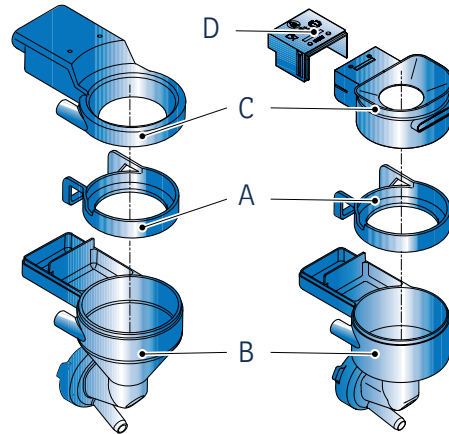

LIQUID RESIDUE TRAY

- 1 Raise the soluble product chute (D).
- 2 Remove the tube (A) from the mixer.
- 3 Turn the mixer fixing lever (B) counterclockwise.
- 4 Remove the mixer (C).

MIXER DISASSEMBLY

Separate all components: funnel (A), mixer ring (B), water conveyor (C) and rear cover (D), if present.

3

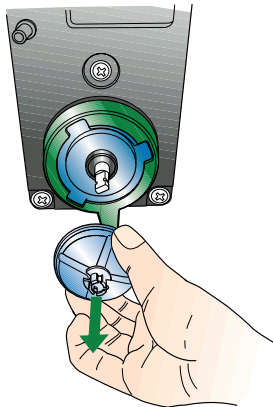

MIXER BLENDER FAN DISASSEMBLY

Gently tug to remove the mixer fan.

4

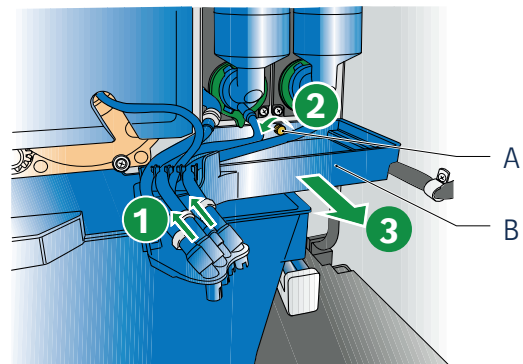

NOZZLE AND MIXER TRAY DISASSEMBLY

- 1 Remove tubes from the nozzles and separate the nozzles from the support.
- 2 Unscrew the knurl (A) of the mixer tray (B).
- 3 Remove the mixer tray.

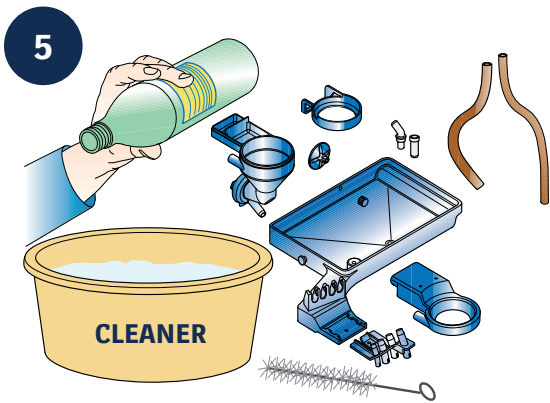

! To avoid altering the taste of drinks, do not use highly scented detergents and/or solvents

COMPONENT SANITIZATION

- 1 Wash all components with a sanitising solution, making sure you remove residues and visible films using brushes and/or brushes.
- 2 Rinse and dry all parts thoroughly.

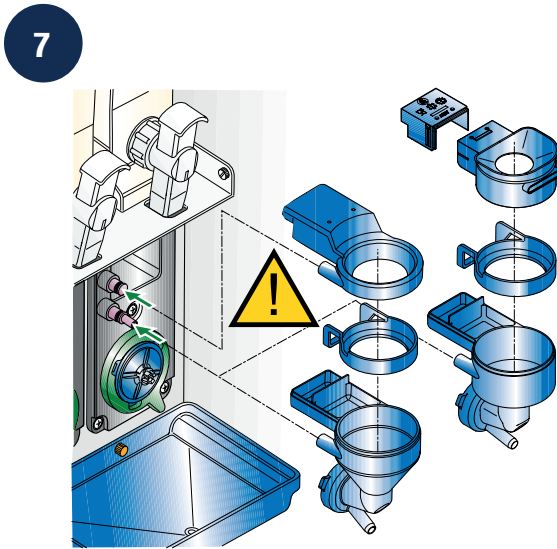

MIXER ASSEMBLY

- 1 Reassemble the components and reposition the mixer.

! Make sure that the couplers are inserted correctly in the mixer.

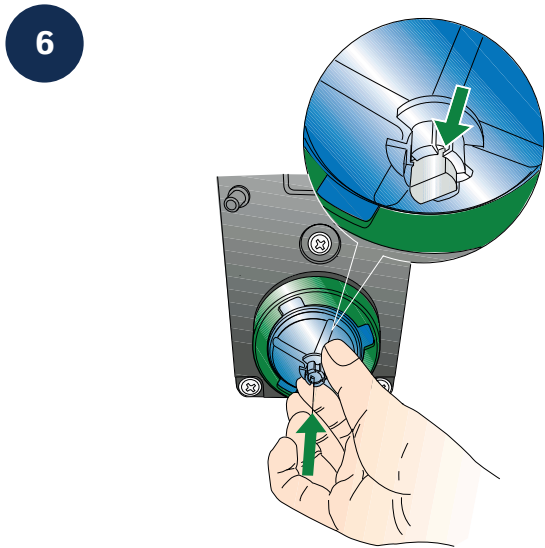

MIXER BLENDER FAN ASSEMBLY

- 1 Reposition and push the mixer fan.
- 2 Make sure it is inserted completely, until it clicks.

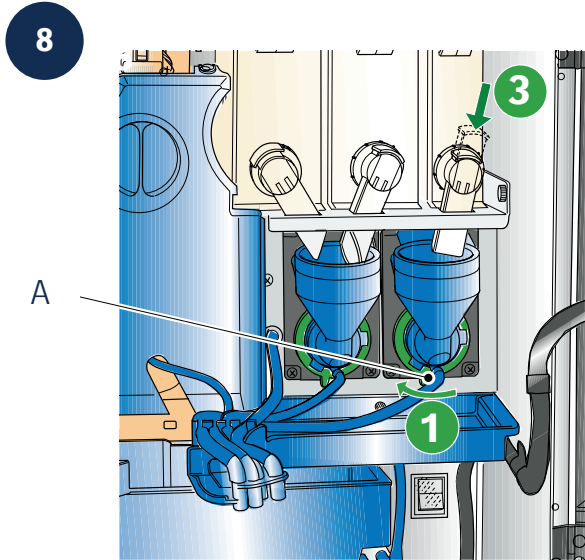

MIXER ASSEMBLY

- 1 Turn the lever (A) clockwise to fasten the mixer to the appliance.
- 2 Reconnect tubes to the mixers.
- 3 Lower the soluble powder chutes.

9

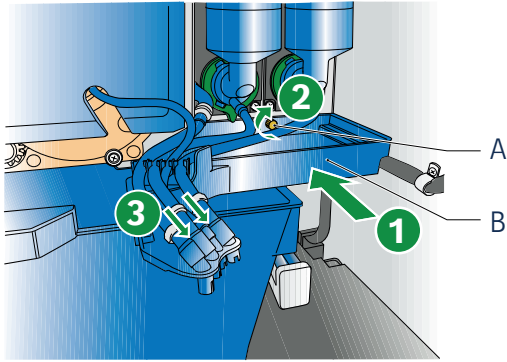

NOZZLE AND MIXER TRAY ASSEMBLY

- 1 Reposition the mixer tray (B).
- 2 Twist on the knurl (A).
- 3 Reposition the nozzles and connect their respective tubes.
- 4 Close the door, then from the “daily operations” functions in the menu, rinse the water system.

10

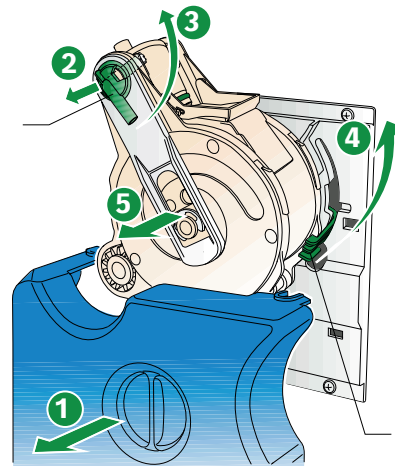

BREWING UNIT CLEANING ASSEMBLY AND CLEANING

- 1 Remove the cover from the brewing unit.
- 2 Turn the coffee outlet nozzle (A) 90° and pull it towards you.
- 3 Operate the group stop lever (B) by turning it horizontally.
- 4 Remove the coffee group.

11

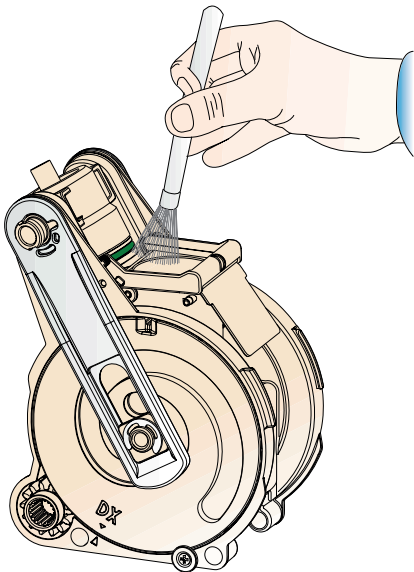

BREWING UNIT CLEANING

- 1 We recommend removing coffee residues from and around the brewing unit at every loading or at least weekly.
- 2 Dust residues off using a brush or a small vacuum cleaner.
- 3 Rinse the brewing group under a water jet.
- 4 Reposition the brewing group following the operations in reverse order.

OPERATED BY

LAVAZZA

PROFESSIONAL

To learn more about the Lavazza Professional
Vending Machine Range & Drinks Products

Call **0800 0323 444**
email **uk.sales@lavazzapro.co.uk** or visit
www.lavazzapro.co.uk